



# **APARTMENT OPERATING AND MAINTENANCE INSTRUCTIONS**

HOAS  
PASILANRAITIO 6  
3/2020

# TABLE OF CONTENTS

1. DOMESTIC APPLIANCES.....	1
1.1 Electric stove .....	1
1.2 Refrigerator .....	10
1.3 Stove fan .....	14
1.4 Dishwasher installation .....	15
2. APARTMENT SURFACES .....	16
2.1 Floors .....	16
2.2 Walls and ceiling .....	17
2.3 Tiles.....	18
2.4 Doors.....	19
2.5 Windows.....	20
3. FURNITURES.....	21
3.1 Bathroom.....	21
3.2 Kitchen .....	22
3.3 Kitchen sink .....	23
3.4 Bathroom toilet and sink .....	24
3.5 Faucets and hand showers.....	25
3.6 Bathroom chrome pipes.....	26
4. TECHNICAL INSTRUCTIONS .....	27
4.1 Thermostat .....	27
4.2 Fire alarm .....	28
4.3 Sink water lock .....	29
4.4 Kitchen leakage alarm .....	31
4.5 Window fresh air valves.....	32
4.6 Air valves.....	33
4.7 Floor drain .....	34
4.8 Electric Central .....	35
4.9 Light bulbs .....	36
5. GUIDE FOR RESIDENTS.....	37

# 1. DOMESTIC APPLIANCES

## 1.1 Electric stove

### SAFETY INFORMATION

Read the instructions that came with your device before installing or using the device. The manufacturer assumes no responsibility for personal injury or damage caused by incorrect installation or use. Always keep the instructions in a safe and accessible place for future use.

#### SAFETY OF CHILDREN AND UNSKILLED PEOPLE

**WARNING!** Risk of choking, personal injury or permanent disability

- Children and people with physical, sensory or mental disabilities may only use the device while being supervised by the person, who is responsible for their safety, only after they have been directed to use the device safely and have understood the hazards associated with its use.
- Do not allow children to play with the appliance.
- All packaging should be disposed properly and kept out of reach of children.
- Keep children and pets away from the appliance when it is in operation or cooling down. The tangible parts of the device are hot.
- Children should not clean or carry out maintenance on the appliance.

#### GENERAL SAFETY INSTRUCTIONS

- A qualified professional can only replace the cables.
- This unit must be connected to the electricity network with a H05VV-F- type cable that resists the back panel temperature.
- Do not install the appliance behind the furniture door so that it does not overheat.
- Do not install the appliance on a cabinet.
- Do not use this machine with an external timer or remote control system.

**WARNING!** Cooking with grease or oil without supervision can be dangerous and may result in fire.

- Never attempt to extinguish fire with water. Switch the appliance off and then cover the flames for example with a lid or a fire blanket.
- **NOTE!** Food preparation should be monitored. Short-term food preparation must be monitored constantly.

**WARNING!** Fire hazard: Do not store anything above the hob.

- Do not use a high pressure cleaner for cleaning the appliance.
- Do not use scourers or sharp metal screws to clean the hobs glass hood or hinged glass hoods as they might scratch the surface, which may result in the glass breaking.
- Metal items such as knives, forks, spoons, and covers should not be placed on the cooktop as they may heat up.

**WARNING!** The appliance and the visible parts will heat up during operation. Be careful not to touch the oven heating resistors. Children under the age of eight should be kept away from the device unless they are constantly monitored.

- Always use oven gloves when handling accessories or oven vents.
- Disconnect the plug from the wall socket before starting maintenance.
- Before replacing the lamp, make sure the appliance is switched off. This will avoid a potential electric shock.
- If the power cord is damaged, the manufacturer, an authorized service center or a qualified person may only replace it in order to avoid an electric shock.
- Be careful when touching the storage box. It can heat up.
- Remove the support rails by first pulling the front part of the support rail and the removing the rear part of the side walls. Reattach the support rails by repeating the steps in reverse order.
- The power cut-off device must be integrated in permanent wiring according to the wiring rules.

**WARNING!** Only use cooktop covers, which are designed by a home appliance manufacturer. Using defective covers can lead to accidents.

## **SAFETY INSTRUCTIONS**

### USE

**WARNING!** Fire and personal injury hazards. Risk of electric shock.

- This appliance is intended for household use only.
- Do not change the technical features of the appliance.
- Make sure there are no obstructions in the ventilation openings.
- Don't leave the appliance unattended during operation.
- Turn the appliance off after each use.
- Open the appliance door with caution while the appliance is in operation.  
Hot air may come from the unit.
- Do not use the appliance with wet hands or when in contact with water.
- Do not use the appliance as a countertop or storage.
- Hot fats or oils can produce flammable vapors. Keep flames or hot objects away from fats and oils when using them for food preparation.
- These vapors, which are produced by hot fats or oils, can cause a fire.
- Used oil, which may contain residues of food, may cause a fire at a lower temperature than oil, which is being used for the first time.
- Do not place flammable objects or objects, which have been soaked in a flammable substance inside, near or on the appliance.
- Do not allow sparks or open fire to enter the appliance when opening the door.
- Open the appliance door with caution. Substances containing alcohol can easily develop a flammable mixture of alcohol and air.

- Prevent enamel damage or color changes:
- Do not place pans or other objects directly on the inside of the bottom of the appliance.
- Do not place water directly in the hot appliance.
- Do not store damp containers or dishes on the appliance after use.
- Be careful when removing or attaching accessories
- The color change of the enamel surfaces of the oven or the stainless steel do not affect the operation of the appliance.
- Do not keep hot cookware on the control panel.
- Do not let saucepans boil until dry.
- Do not allow items or kitchenware to fall on the appliance, the surface might be damaged.
- Do not switch the cooking zones on while the cookware is empty or if there is no cookware on the cooking zones.
- Do not place aluminum foil on top of the appliance or directly on the bottom of the inside of the appliance.
- Food should not be prepared directly on the cast iron cooktop. Food is to be prepared using appropriate cooking utensils.
- Cookware made out of cast iron or aluminum or ones that have a damaged base, can scratch the surface. Always lift cookware from the hob before moving it.
- This appliance is intended for cooking only. It must not be used for other purposes, such as heating the room.

## **TREATMENT AND CLEANING**

**WARNING!** Risk of personal injury, fire or damage to the device

- Disconnect the appliance before maintenance. Disconnect the plug from the socket.
- Check that the appliance has cooled off. There is a risk that the glass panels may break.
- Immediately, replace defective door glass panels. Contact an authorized service center.
- Fat or food left in the appliance can cause a fire.
- Clean the appliance regularly to avoid damaging the surface material.
- Clean the unit with a damp, soft cloth. Use only mild detergents. Do not use abrasives, abrasive washers, solvents or metal objects.
- If you are using an oven cleansing solution, follow the safety instructions on the packaging.
- Do not clean the catalyst enamel (if present) with a detergent.

## **INTERIOR LIGHT**

- Use only light bulbs or halogen lamps for household appliances. Do not use them to illuminate the room.
- Before replacing the lamp, the appliance must be disconnected from the socket.
- Use only lamps with the same characteristics

## **MAINTENANCE**

- When the machine needs to be repaired, contact an authorized service center.
- Only use original spare parts.

# DESCRIPTION OF THE DEVICE

## PARTS OF THE APPLIANCE

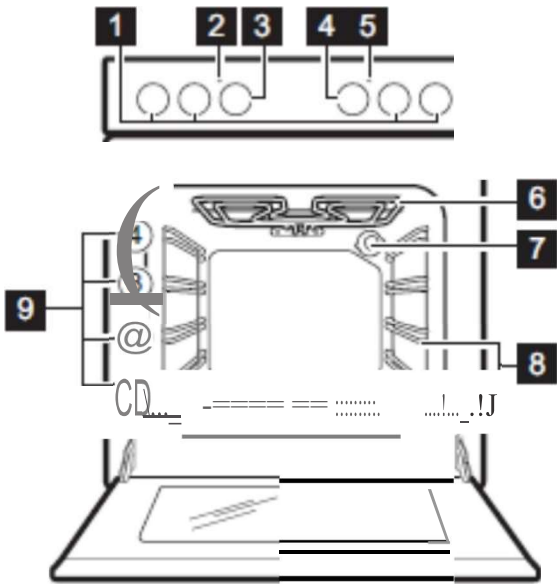

1. Cooker switches
2. Temperature indicator / symbol
3. Temperature selector
4. Knob for oven functions
5. Cooker level light / symbol
6. Heat insulation
7. Light
8. Detachable support rail
9. Support levels

## COOKING ZONES

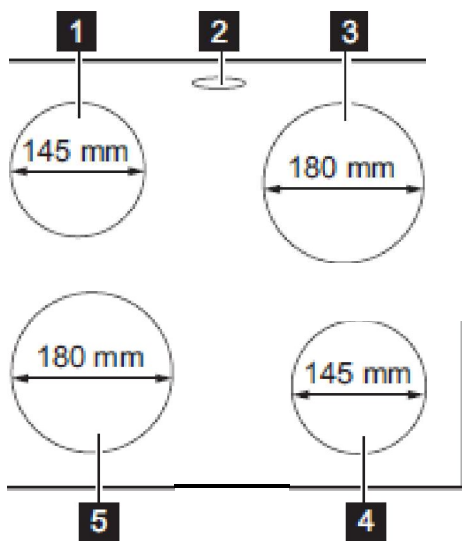

1. Cooking zone 1000 W
2. Steam opening - the number and location depends on the model
3. Cooking zone 1500 W
4. Cooking zone 1500 W
5. Cooking zone 2000 W



## **HOB – TREATMENT AND CLEANING**

### GENERAL INFORMATION

- Clean the hob after each use.
- Always check that the bottom of the container is clean.
- Scratches or dark spots on the surface do not affect the operation of the hob.

### STAINLESS STEEL

- Clean the stainless steel parts with cleansing solution, which is meant for stainless steel.
- The stainless steel edges around the hot plates may stain slightly due to high temperature.
- Wash the stainless steel parts with water and dry them with a soft cloth









### CLEANING THE ELECTRIC PLATE

1. Use a cleaning powder or a cleaning brush.
2. Clean the hob with a damp cloth using a little detergent.
3. Heat the hot plate to low heat and allow it to dry.
4. The hot plates can be kept in good condition by rubbing them regularly with sewing machine oil. Wipe the oil away with absorbent paper cloths.

### CLEANING THE STOVETOP

To clean the stove fan, lift the stovetop upwards and pull it towards you. When putting the stovetop back in place, make sure that the lever on the wall hits the opening on the back of the stovetop. The stove top wont stand in place if they are not connected properly.

## OVEN FUNCTIONS

<b>Symbol</b>	<b>Oven funcion</b>	<b>Intended use</b>
	Switched off	The appliance has been switched off
	Oven lamp	Lighting the lamp without turning the oven on
	Upper and lower heat	Cooking or baking on one level
	Light baking	Preparing special pasteries
	Lower heat	Baking and preserving crispy cakes
	Max grill	Grilling high quantities of food and roasting bread
	Fast heating	Baking roasts on one level. Maximum temperature 210 degrees Celsius
	Low heat	Slow cooking

# OVEN – CARE AND CLEANING

## CLEANING

- Clean the front surfaces of the unit with warm water and a mild detergent using a soft cloth.
- Use a special cleaning solution for cleaning metal surfaces.
- Clean the appliance after each use. The accumulation of fat or other food can result in fire. The risk is greater when using a grill pan.
- Remove persistent stains with a special oven cleaner.
- Clean all accessories after use and allow them to dry. Use a soft cloth, warm water and a cleaning solution.
- If you are using unobtrusive equipment, do not clean them with strong detergents, sharp-edged objects or wash them in the dishwasher.  
Otherwise, the surface may be damaged.

## STAINLESS STEEL AND ALUMINUM SURFACES

Clean the oven door using only a damp cloth. Dry with a soft cloth. Do not use steel wool, acids or abrasives as they may damage the surface of the oven. Observe the same caution when cleaning the operator panel.

## REMOVING THE BRACKETS

Clean the oven by removing the brackets.

1. Pull the front of the blade support bracket off the sidewall.
2. Remove the back of the blade support bracket from the wall and remove it.

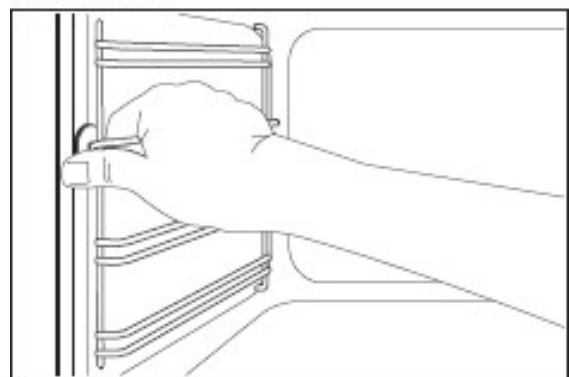

# 1.2 Refrigerator

## **SAFETY INSTRUCTIONS**

### USE

**WARNING!** Risk of personal injury, burns, electric shock or fire

- Do not change the technical features of the device.
- Do not place electrical appliances in the unit unless the manufacturer has authorized them.
- Make sure the cooling pipe is not damaged. It contains isobutene, which is environmentally compatible with natural gas. This gas is flammable.
- If the cooling pipe is damaged, make sure there are no open fires or ignition sources in the room. Make sure the room is ventilated.
- Do not allow hot objects to touch the plastic parts of the device.
- Do not place soft drinks in the freezer. Otherwise, pressure is generated in the beverage container.
- Do not store flammable gases or liquids in the appliance.
- Do not place any objects that are flammable or soaked with a flammable substance on top, inside or near the appliance.

## **TREATMENT AND CARE**

- Disconnect the appliance and remove the plug from the socket before starting maintenance.
- The appliances cooling unit contains hydrocarbons. Only a qualified professional is allowed to service and re-fill the unit.
- Regularly check the outlet of the appliance and clean it if necessary. If the outlet is blocked, melted water will accumulate on the bottom of the appliance.

## USE

### Launching the device

- Plug the appliance into the socket. Turn the temperature control clockwise to the middle position

### Switching the device off

- The appliance is turned off by turning the temperature controller to "0".

### Temperature adjustment

The temperature is adjusted automatically. The device is used as follows:

- Set the temperature higher by turning the temperature knob towards lower set points.
- Set the temperature lower by turning the temperature knob towards higher set points.

**ATTENTION!** The middle position is usually the best

Observe the following things when it comes to adjusting the temperature:

- The room temperature
- The opening frequency of the door
- The quantity of food that is stored
- The location of the device

**ATTENTION!** Do not use cleaning solutions, abrasives, chloride or oil based substances. They might damage the surfaces.

## **DAILY USE**

### Freezing fresh food

The freezer compartment is suitable for freezing fresh food and for long-term preservation of ready-made frozen foods. When you freeze fresh foods, you do not need to change the average setting. However, you can speed up the freezing process by turning the temperature controller to the lowest position.

### Care and cleaning

#### Regular cleaning

The appliance must be cleaned regularly.

1. Clean the interior and the equipment with warm water and detergent.
2. Check the door seals regularly and wipe them clean.
3. Rinse and dry thoroughly.
4. If possible, clean the condenser and the compressor at the back of the appliance with a brush. This operation improves the performance of the device and saves energy.

### Defrosting the freezer

**ATTENTION!** Never use sharp metal objects to remove frost from the evaporator, as this may damage it. Do not attempt to speed up the defrosting using mechanical or other tools that the manufacturer has not advised to use. The temperature of the frozen food rises during thawing and may shorten their safe storage time.

Set a lower temperature about 12 hours before the start of defrosting to freeze to make sure the frozen produce is as cold as possible and then store them in a cold place during the defrosting.

The freezer compartments and the upper compartments produce some frost. Defrost the freezer, when the thickness of the frost is about 3-5mm.

1. Disconnect the appliance or unplug the appliance.
2. Remove all food from the freezer, wrap them in thick paper and place them in a cool place.

**WARNING!** Do not touch frozen foods with wet hands. Hands might freeze to the food.

3. Leave the door open. To speed up thawing, place a container with warm water inside of the freezer. Also, remove ice cubes from the freezer during defrosting.

4. After the freezer compartment has melted, dry the inner surfaces well.

5. Turn the machine back on.

Place the frozen foods back in the freezer after 3 hours.

## **Defrosting the refrigerator**

In normal operation, the frost automatically goes out of the refrigerator compartments steam generator when the compressor stops. Defrosting water is poured on the back of the appliance inside of the drawer on top of the compressor, from where it evaporates.

It is important to clean the defrosting water drainage hole in the middle of the refrigerator section channel regularly, so that the water does not overflow and drip on the food.

If the appliance is not used for a long time

If the appliance is not going to be used for a long time, do the following:

1. Disconnect the appliance from the mains.
2. Remove all food.
3. Defrost (if necessary) and clean the appliance and all its accessories.
4. Clean the appliance and all its accessories.

Leave the door closed to avoid unpleasant odors inside of the appliance

## **ATTENTION!**

**A leakage protection is installed under the refrigerator to direct possible waterleakage visible. If you notice water, contact HOAS Service.**

# 1.3 Stove fan

**ATTENTION! APARTMENTS D83-D85 HAVE DIFFERENT MODEL**  
(See next page)

## Vallox X-Line KTX



### USING VENTILATION

For buildings with a centralized ventilation system.

The air flow of the KTC cooker hood is adjusted during setup using a joint duct valve that is installed on the hood and also serves as a fire damper.

### USING THE UNIT

The cooker hood is designed to be used above the cooker top and as a general extraction valve in the kitchen.

The cooker hood has a sliding glass that can be pulled out of the cooker hood. It is recommended that the sliding glass be pushed or pulled from the aluminum strip on its front edge. Pull the glass out of the cooker hood for maximal extraction capacity.



#### Cooker hood light

Turn the light on or off by pressing the light switch.

### MAINTENANCE

Keep the cooker hood clean. Wipe outer surfaces regularly with water containing a small amount of a mild detergent. Clean off any grease stains immediately. Do not use abrasive or corrosive detergents or tools.

Keep the grease filter clean to ensure an adequate extract air flow. The grease filter must be washed with warm water and detergent at least 1-2 times a month.

#### Light

The cooker hood has a long-lasting LED lighting module. If the light is not working, contact a servicing company.



#### PLEASE NOTE!

- Neglecting the cleaning of the grease filter can cause a fire hazard.
- The outer surfaces of the hood can become hot when the cooker or the oven is turned on.
- Flaming is forbidden underneath the cooker hood.
- Always follow the instructions provided on adjusting the efficiency of ventilation.
- Enable a sufficient supply airflow into the room if the cooker hood and non-electric devices are used simultaneously.



#### WARNING!

The unit is not intended for use by children under 8 or by persons with reduced sensory, physical or mental capabilities, or whose lack of knowledge and experience do not ensure safe operation of the unit. Such persons can use the unit under supervision, or by following the instructions of someone who is responsible for their safety. Do not let children play with the unit or to clean or maintain it without supervision.

#### Removing and mounting the grease filter



Removing the filter



Mounting the filter

- Pull the locking device of the grease filter towards the front edge of the cooker hood while pulling the grease filter downwards until it comes off.
- Wash the grease filter and leave to dry.
- Mount the grease filter back in place. Push the front edge of the filter into the pins on the cooker hood, and click the rear edge in place.

**NOTE! Ensure that the locking device points downwards.**



# **1.4 Dishwasher installation**

## **Instructions for removing the storage cabinet**

If you want to install the dishwasher, you must disassemble the cabinet with the following instructions below.

1. Remove the lower plinth from the washing machine charge.
2. Unscrew the cabinet frame and remove the cabinet. Remember to keep the cabinet frame.
3. Install the dishwasher. All the necessary holes and routes for the dishwasher cord and the inlet and outlet hoses are ready.

## **Dishwasher installation**

The installation of the dishwasher must be done by a certified plumber. The dishwasher space must be fitted with a plastic mat with raised edges about 100 mm. Connections to the water and sewerage network must be made with fixed connections and shut-off valves to the water supply.

# 2. APARTMENT SURFACES

## 2.1 Floors

### DAILY CLEANING

For daily cleaning, use dry methods, e.g. vacuuming or micro mop.



### REGULAR MAINTENANCE

Make sure that the surface is free from any dirt or debris that may scratch the surface, by vacuum cleaning or dry mopping. Dissolve the Cleaner in lukewarm water according to dosage information on the bottle. – or use the ready-to-use Kährs Spray Cleaner.

Damp-clean the floor as necessary using a well-wrung mop or floor cloth. Only dampen the floor

slightly. The film of water left by the floor cloth must dry within a minute. Do not allow spilled water to remain, especially on Beech and Hard Maple (Canadian Maple) floors because they are particularly sensitive to moisture. The frequency of damp cleaning depends on the usage and soiling.

**Note: Never pour water onto wood floors. Use a cloth dampened with water and squeezed dry.**

### STAIN REMOVAL

Remove stains as soon as possible following the advice given below.

Use strong stain-removers with care, because using too much or rubbing too hard can affect the finish.

Do not allow spilled water to remain on the floor, especially on Beech and Hard Maple (Canadian Maple) floors.

STAIN	REMOVE WITH
Asphalt, rubber, oil, shoe polish, soot and dried residues of chocolate or grease.	Alcohol, petroleum ether or similar.
Crayons, lipstick, felt tip pens.	Alcohol.
Candle wax, chewing gum.	Freeze-spray or put a plastic bag of ice cubes on the mark. Then scrape off carefully.
Blood.	Cold water.

## 2.2 Walls and ceiling

Before you start, ensure the tools you're using, from sponges to cloths to dust mops won't scratch the paintwork. Soft sponges and soft cloths are what's needed.

Dust off any excess dirt before starting to clean painted walls, otherwise you will just spread the grime. You can do this using a lint-free cloth for those areas you can reach, and a soft broom with a rag over its bristles or, better still, a dust mop (we rate the e-cloth deep clean mop) for any high areas.

In most cases, all you need for this is warm, soapy water. Create a cleaning solution in a bucket using water and your mildest cleaning detergent. Use your softest sponge to apply the solution to your walls. Don't over soak the sponge. If you do, wring it out properly before cleaning as dripping can potentially leave water stains on your walls. Leave for five to 10 minutes.

If certain parts of your ceiling are exceptionally dirty, you may need to use a dry microfiber cloth to wipe them. Take your cloth and gently pat or wipe the area.

Avoid applying too much pressure so as not to rub dirt or dust into the ceiling.

Get a new cloth once the one you are using is dirty.

If you can't reach the ceiling, use a chair, ladder, or take a broom and fix your microfiber cloth to the end of it.

Vacuum the ceiling. Simply take the vacuum and gently run it along the surface of the ceiling. Depending on the type of vacuum you have, you may be able to vacuum a substantial amount of debris before doing anything else.

Use a bristle-brush attachment or another attachment intended for easily-scratched surfaces.

Extend the telescoping shaft of your vacuum, if you have one.

Pay special attention to corners, where crown molding meets the ceiling, and areas around air vents.

## 2.3 Tiles

### General

The cleaning and care instructions cover the care and cleaning of ceramic tiles, natural stones, cement tiles and terracotta tiles. When using cleaning and care products make sure that the manufacturer's operating and safety instructions are followed. Test the suitability on a small area in a corner, for example before use. In our cleaning and care instructions, we recommend Geal-products, which come directly from us. The stress on the tiles in different areas should be evaluated and a surface cleaning and care plan should be done. The plan should include at least each individual material as well as their cleaning methods and the substances going to be used.

### **Daily cleaning, stain removal, renewal of protection:**

For regular cleaning, use CB90 neutral detergent (2-5% mixture). For thorough cleaning, use CB90 with 50% solution or alkaline power cleaner, Super Deterjet- detergent or acidic Service Ceramic- detergent (for lime precipitation) as directed. Select the roughness of the cleaning device according to the amount of dirt. Rinse the floor with water after cleaning. Remove excess water and detergent residues. After thorough cleaning, the floor protection process needs to be renewed. Use the Progres No-Lux products to restore the original protection power.

### **ATTENTION!**

**It is not allowed to make holes in the bathroom walls and floor.**

## 2.4 Doors

### Care and maintenance instructions for interior doors

The painted and varnished surfaces of the interior doors and kernels, tolerate normal substances used in households such as water, soft drinks, alcohol, oils, fats and other nutrients well. However, prolonged exposure of surfaces to external agents must be avoided.

### Cleaning doors

The surfaces are cleaned as soon as possible after fouling, so that they can be cleaned more effortlessly. Clammy or moist scrubbing with a cleaning cloth moistened with dishwashing liquid is usually sufficient. After the moist scrubbing, the door surface must be dried. Keep the duration of action of chemicals as short as possible. Remove the dye and water-insoluble stains with heavy naphtha or denatured spirit and finally wipe the area with a damp cloth. Severe stains, as well as traces of heat and moisture, can be carefully rubbed with a furniture wax.

### Do not use:

strong solvents (for example acetone and paint thinner), because they might soften the varnish and paint  
abrasive detergents and washing utensils (matt and semi-matt lacquered surfaces are most sensitive to abrasion)  
detergents containing ammonia  
strongly alkaline or acid cleansers

Avoid long-acting fluid effects, water use, hot objects and hot water. Avoid using waxes as their removal might cause difficulties. Also, note that uneven mechanical stress on the surface often results in an uneven gloss.

### Maintenance of hinges, locks, gaskets and ferrules

Due to wood being a living substance, the tightness of the hinging screws should be checked within one year of the installation of the door.

The door locks are to be lubricated regularly, so they work properly. Various oils can be used for lubrication. The poles are lubricated on either side, the key cavity and the root of the possible torque.

The seals are mainly made of silicone or EPDM-rubber. The seals do not require special maintenance; regular cleaning when cleaning the door is sufficient. The seals should be checked regularly. If the seals are broken, they must be replaced.

## 2.5 Windows

In addition to the window cleaner, the usual mild dishwashing detergent is suitable as a window cleaner. After the actual wash, rinse the glass with clean water.

Special care should be taken to dry the corners. Never use a high-pressure washer to clean windows, as moisture is easily trapped between seals or wall insulation under high pressure.

Stains can be wiped with a damp cloth. Alkaline detergent, such as dishwashing detergent, can be added to the wash water. The use of strong solvents should be avoided as they may dull paint surfaces. Special care must be taken when cleaning coated glasses. If you know your window has a coating, especially avoid abrasive tools.

Hard stains such as silicone and adhesive should be removed by scratching first. Suitable so-called. Handy blades can be found in hardware stores and tool shops. After scratching, wipe the window clean with a white dry cloth.

The remaining stains can be removed lightly by rubbing with a cloth moistened with, for example, white spirit or turpentine. Silicone stains work best with acetone or xylene, both of which are sold at hardware stores.

# 3. FURNITURES

## 3.1 Bathroom

### **MIRROR AND LIGHT MIRROR CABINETS**

Mirror and light mirror cabinets are made of powder painted steel, so cleaning with standard detergents enough. Cleaning should not be done with abrasive powder or liquid, the paint finish of the product may be damaged.

#### **Mirror surfaces**

You can clean it with glass detergents. Periodically check the mirror doors and hinged screws for tightness and tighten if necessary.

IMPORTANT! Be sure to perform the RCD test. Help is located next to the outlet.

### **REPLACEMENT OF FLIGHT LAMP AND LIGHT LAMP MIRROR CABINETS**

You can replace a faulty fluorescent lamp and a lighter without tools:

- switch off the lamp
- gently squeeze the bottom of the plastic cover with your thumb so that the edge comes off its groove
- the plastic cover comes off
- Grasp the fluorescent lamp and pull it out of its holder
- the new fluorescent lamp is pushed into its holder as far as the click sound indicates locking
- first insert the lower edge of the lamp cover into its groove and gently squeeze it again from the top, then push into the upper groove.

NOTE! Electrical failure only for repair by a qualified electrician!

#### **SOCKET**

Your lamp cabinet has a shielded socket where you can keep your electrical equipment charged at all times.

Electrical equipment may be outside the cabinet, allowing you to insert the plug and the cord into the cabinet

socket between the mirror and cabinet body - first loosen the screws on the mirror hinge and carefully move the mirror so that

that the lead fits in between; Finally, replace the mirror and tighten the screws.

#### **SINK**

Sinks are cleaned with neutral detergents and sponges or brushes for cleaning. Do not use any abrasive detergents or detergents. Do not expose the product to acids, ammonia-containing sewage cleaners, hair dyes and chlorine. Purification can use, for example, the Clean & Shine cleaning and care product found in hardware stores, which is also suitable for porcelain marble basins.

#### **Shower glass wall**

Dirt and stains are removed from the glass with a standard sanitary cleaner or dishwashing detergent using plenty of water. After rinsing the glass Thoroughly dry with a spatula to avoid stains. Smudges occur when the tap water dries, leaving the glass white stains. Any stains are removed with a mild detergent. The stains can be rubbed with a cloth and give financial ethics

influence. Repeat the treatment if necessary. Finally, rinse the glass thoroughly water and dry with a soft cloth. Note. Avoid hitting the vinegar solution wall profile and fittings.

The other parts of the shower wall can be cleaned with a mild suitable for the purpose with liquid detergent and a soft cloth. Abrasive, abrasive, cleaners containing acids or ammonia must not be used to the shower wall glass or other parts.

## 3.2 Kitchen

### Doors

- Doors can be lightly wiped with a damp cloth. If the stain does not come off with just plain water, washing can be enhanced with standard household detergents.
- However, do not use abrasive materials or substances or organic solvents.
- Do not expose the door to hot steam. The door has a heat resistance of 80 C.
- Both sides of the hob have heat strips designed to prevent the effect of heat on adjacent furniture.
- The toaster and the coffee and kettle must be placed in such a way that the heat coming from them is not directly accessible to the furniture.

### Worktop and intermediate space

- The level / intermediate space is usually cleaned with hand dishwashing detergent. The level / intermediate space does not withstand abrasive / abrasive cleaning agents or hard mechanical cleaning with eg steel wool.
- Stubborn stains can be cleaned with household spirit, acetone or thinner by wiping with a cleaning towel, not rubbing. NOTE! These products should not be used to clean the edges of the plastic or wooden strip laminate.
- The level / intermediate space is resistant to scratches with sharp objects. The platform cannot be used as a cutting deck.
- Do not place hot containers directly on the level, as this may damage the surface.
- The oven vapor removal should not be pointed at a close distance directly to the laminate surface. Make sure the steam of the dishwasher does not condense on the underside of the counter and cause moisture damage.
- Edges and joints on laminate countertops are momentarily splash-proof. Stagnant waters must be wiped away from the edges of the railings within a reasonable time.
- If changes or defects in the levels are noticed, they must be addressed immediately and corrected as necessary to prevent major problems.

## ATTENTION!

**The sink cabinet is equipped with a leak alarm, the instructions can be found in the technical documentation**



## 3.3 Kitchen sink

### Stainless steel care instructions

1.

#### AFTER INSTALLATION

##### Remember to protect the surfaces!

- Cover the product carefully with cardboard or other suitable material to avoid damaging the product before use.
- Do not leave tools or such on top of uncovered surfaces.
- Do not use strong chemicals that could damage the surface.

!

#### SCRATCHES

Use of stainless steel surfaces always results in minor scratching, and the scratches are most visible on the surface of a brand-new product. With regular use the surface area will scratch throughout, and the surface will appear dimmer. Eventually single scratches will not stand out.

Surface scratching of stainless steel during normal use will not cause any deterioration in the product. The sink is protected by an oxide layer that forms on the surface. When scratches occur on the surface, the oxide layer is renewed by the action of oxygen in the surrounding air.

#### SUBSTANCES TO AVOID

Acidic substances, such as **kitchen soaps containing citric acid**, may damage stainless steel surfaces after they dry (pH under 6).

Scouring powders and steel wool will scratch the surface.

2.

#### BEFORE USE

Wash the product with an alkaline washing detergent (pH over 8). Rinse well and dry.

##### Note!

Small particles on the stainless steel surface from installation may appear as rust spots. Remove these impurities from the surface with a careful cleaning using an alkaline detergent, such as Cif cream or Universal Stone.

Spread the detergent with a soft cloth or miracle sponge, **let sit for 15 minutes**, then rinse carefully and dry. Once the impurities are removed from the surface, the chromium included in the stainless steel will react with oxygen and create a passive layer to protect the surface.



3.

#### CARE: WASH, RINSE AND DRY

Always after use, wipe the surface clean with a soft cloth, sponge or towel. Use warm water and a liquid detergent for cleaning. Rinse well with water and dry with a soft cloth.

#### Instructions for stain removal

##### Tough stains

##### Grease stains

##### Discoloration caused by coffee or tea

##### Salt and lime marks

##### Rust stains from surface contact

Use a cleaning paste (e.g. Cif cream or Universal Stone) with a soft wash cloth or miracle sponge and rinse with warm water.

Dried up lime stains can also be removed by using a 25% vinegar solution. Allow the solution to sit for a while. Then clean, rinse and dry the surface.

#### REMEMBER!

Do not leave a wet cast iron pan or other metallic kitchen utensils that can rust on the surface for extended periods, for they will leave a mark.

#### RECYCLING

Stainless steel contains valuable raw materials like chromium and nickel. Recycle the product with metallic waste. Plast from siphon can be recycled as energy waste.

Tip! Re-use stainless steel worktop or sink as a summer cottage or terrace cooking area.

## 3.4 Bathroom toilet and sink

### SANITARY PORCELAIN MAINTENANCE INSTRUCTIONS

#### What is sanitary porcelain

IDO has manufactured porcelain for more than a century. In production both the customer as well as the environment are taken into consideration. Sanitary porcelain is produced of natural raw materials: clay, kaolin, feldspar, and quartz. The products are fired at a temperature of over 1200 C° resulting in compact porcelain covered with a glossy and hygienic surface.

#### Maintenance instructions

The hard and glossy surface is easy to keep clean. We recommend regular cleansing of the WC with a brush. For cleaning we recommend ordinary detergents with a pH-value below 10. If the toilet bowl walls have become stained the bowl should be cleansed without delay. WC- or common detergents will be adequate for this purpose.

Organic substances conducive to bacterial growth adhere to the visible and invisible surfaces of the water trap. Therefore it is necessary to clean the water trap regularly with a bactericidal WC-detergent following the manufacturer's instructions. After flushing a trickle of water usually runs down along the back surface of the toilet bowl for a while. For preventing minerals contained in the water from adhering to the inner walls of the bowl an acid detergent (pH-value 1-3) should be used. In case of continual leakage a qualified plumber should be called.

If the porcelain surface has become heavily stained and cannot be cleansed with ordinary sanitary detergents, then solutions containing acetic or citric acid should be tried.

When applying these substances you should note, that

- the solution must be diluted with water (a slightly stronger solution can be used for the WC water trap, the water capacity of which is 1,5-2,0 l depending on the model).
- remember to protect your skin and especially your eyes.
- do not allow any solution to dry upon the porcelain surface, but remove it immediately by brushing after spreading the substance, and flush the surface.
- plastic or other surfaces than porcelain should be protected from contact with the solution.

#### What substances should not be applied to sanitary porcelain surfaces?

Do not use detergents containing scouring powder, steel wool, or rough cleaning pads containing ceramic grinding components. Neither do we recommend agents containing lye (sodium hydroxide) or hypochlorides (chlorine-based detergents) with a pH-value over 10 (strongly alkaline detergents). Furthermore, do not use strong acids like hydrochloric or sulphuric acid, or strongly alkaline lye-based chemicals used for opening clogged drainpipes. These agents burden the environment considerably. Also strong chemicals like solvents, other toxic substances as well as paints should not be poured into the WC-bowl since they can damage the WC-surface and also the environment.

#### Detergents or other chemicals should not be poured into the water cistern, since this may damage the plastic parts.

In buildings left unheated for the winter the WC-cistern must be emptied and dried thoroughly. Pour 3-4 dl of anti-freeze solution into the water trap. Then cover the water trap with cooking oil or plastic foil to prevent evaporation.

## 3.5 Faucets and hand showers

A damp cloth and mild liquid dishwashing soap may be used for a limited amount of time, followed by rinsing with water and drying with a soft cloth. Most common household cleaners (including mild abrasives) can be used, when used in accordance with the manufacturers' instructions for use.

All cleaners should be rinsed off thoroughly with water immediately after cleaning your faucet. Avoid using any harsh cleansers (e.g., lime scale removers) or pads/sponges that are unsafe for polished metallic surfaces. Most green, fibrous pads/-sponges contain microscopic mineral particles that can scratch a faucet's finish.

### **ATTENTION!**

If the water becomes brown or cloudy, drain the water until it is clear. Brown or cloudy water is not dangerous.

## 3.6 Bathroom chrome pipes

Add dish soap to a bucket of warm water, dip a soft cloth or nonabrasive sponge into the solution, then get to work scrubbing the chrome. As you go along, rinse the cloth or sponge frequently in order to dispel the dirt that has begun to loosen and break free from the metal. To clean any creases or crevices you come across in the chrome, opt for an old toothbrush; the bristles can work the soapy water into areas you wouldn't be able to reach otherwise. Finish up by rinsing the metal with clean water in order to eliminate any residual traces of soap that remain on the chrome.

More potent than dish soap is distilled white vinegar. Using a one-to-one ratio, mix the vinegar with plain old tap water, then apply the solution by means of a cloth or nonabrasive sponge. Again, use a toothbrush for any hard-to-reach areas. Remember that vinegar works so well on account of its acidity, which dissolves even long-established grime. So as not to dilute its strength, take care not to mix the vinegar with too great a volume of water.

### **Avoiding Damage**

The methods discussed here involve neither harsh chemicals nor heavy-duty cleaning tools. That's because chrome is a soft metal. It can be scratched even by a scouring pad, so avoid the temptation to use a sharp edge on stubborn stains. Also, if you're intent on using a commercial cleanser, be sure that its label says the product is suitable for chrome.

# 4. TECHNICAL INSTRUCTIONS

## 4.1 Thermostat

### Temperature selection

When the temperature selector lever is rotated so that number 3 and the triangle icon are aligned, the room temperature is about 20 degrees Celsius.

Please note that the maximum temperature turns more than number 3. The temperature selector dial is 3 degrees Celsius.

If the handle is later rotated down or up, the room temperature changes slowly in the desired direction.

### Ventilation

Turn the thermostat for the time of ventilation so that the triangle and sun icons are aligned. That way, you do not lose any heat. After ventilation, turn the thermostat back to the desired position.

If you want to lower the room temperature by night, turn the thermostat slightly to a lower temperature.

### Frost protection

The sun icon is meant for frost protection. The thermostat opens when the room temperature goes below 8 degrees Celsius. This is useful, for example, when travelling for a longer period or the room does not need any heating.

### Do not cover the sensor

The thermostat adjusts the room temperature according to the temperature measured by the sensor. The sensor must not be covered with thick curtains, furniture or similar. A detonator is the right solution for concealed radiators.

NB! When the room reaches the desired room temperature, the radiator starts to cool down: The thermostat works, as it should.

The thermostat uses extra heat from the sun, light and the stovetop and increases the comfort of the home.

## 4.2 Fire alarm

In order for the smoke / heat detector to work properly, the detectors should be tested and serviced regularly. The maintenance program takes into account national laws and regulations and complies with the manufacturer's instructions.

### **ATTENTION!**

**RESIDENTS ARE NOT ALLOWED TO CARRY OUT  
MAINTENANCE SERVICES RELATED TO FIRE ALARMS**

## 4.3 Sink water lock

### **Cleaning the water lock**

If you start smelling sewer odor near the sink, it is usually a sign, that the water lock should be cleaned. Another sign is, when the sink does not discharge water normally, the discharge takes longer than usual. If one is experiencing either one issue mentioned above, cleaning the sink water lock is usually the solution.

### **The necessary tools**

For the cleaning process protective gloves (rubber kitchen gloves), a bucket and possibly an old towel or paper towels to clean up the splatters are required. An old dish- or bottlebrush can be used for cleaning the pipes. A disinfecting cleansing solution is usually used when cleaning the water lock.

### **Removing the water lock**

The water lock of the bathroom or kitchen sink is usually attached at two points; on the top and on the side, (the slop enters the water lock through the top joint .

The water lock of the washbasin or the kitchen sink is usually attached at two points; on the top and on the side (the slop enters the water lock through the top joint and the slop exits through the side joint). When the water lock is removed, the side joint is detached first aka the waste pipe.

When detaching the waste pipe, some slop might drip out, so a protective bucket should be placed under the water lock before this step. Next, the top joint is detached and the water lock is pulled down in a controlled matter. The water inside of the trap is poured into the bucket or the toilet. If there is a lot of hair inside of the trap, they should be put in the trash.

### **Things to note when emptying and cleaning the water lock**

The detached water lock can be cleaned easily for example in a bucket. that is halfway filled with water. An old dish- or bottlebrush can be used for help. If the inner surface of the water lock looks very dirty, a disinfecting cleansing solution can be used (typically chloride).

When cleaning the water lock, the pipe entering the drain pipe should also be opened and cleaned (the discharge pipe of the wash-basin) as well as the discharge pipe of the water lock. Particularly the discharge pipe of the washbasin should be cleaned for example with a bottlebrush (if the structure of the washbasin and the discharge pipe allows doing so).

After the water lock and the pipes connected with the slop are cleaned, can the water lock be connected back to its place. Before attaching, the condition of the seals of the water lock and the discharge pipe should be checked; worn out seals can easily be replaced after the cleaning. When the protective cap and

the water lock are reattached, drain water for a couple of minutes to make sure the joints hold.

**Clean also the overflow channel of the washbasin**

Cleaning the water lock is not always enough to remove the unpleasant odors. If this is the case, the washbasin aka the overflow channel should also be cleaned. It is a channel, which tries to prevent the overflow of a fully filled washbasin (it is typically the small hole, which is on the top part of the washbasin).

This channel can be cleaned with a flexible bottlebrush from the top and the bottom. Alternatively, the discharge opening of the channel (the bottom opening) can be clogged temporarily, and the channel can be filled with a cleansing solution (or an odor neutralizing mixture), after which the clog can be removed and the channel rinsed clean. Whatever cleaning method is used, one should make sure, that the method used does not damage the surface of the washbasin. Additionally, the functionality of the channel should be tested after the cleaning is complete.



## 4.4 Kitchen leakage alarm

The leakage and humidity alarm is a battery independent alarm device. The device alarms with a siren leakage, while testing or when the battery voltage drops. The central sensor detects arise between the underside of the copper water and moisture.

### 1. Battery

The device can be switched on and off run with the switch provided. Leakage the humidity alarm functions are reset when switching on. The switch should be Off when replacing the battery.

### 2. On / Off switch

Press this button to test the device alarm siren and relay operation. Remember Perform testing after installation and always during the annual battery replacement.

### 3. Test button

Press this button to test the device alarm siren and relay operation. Remember Perform testing after installation and always during the annual battery replacement.

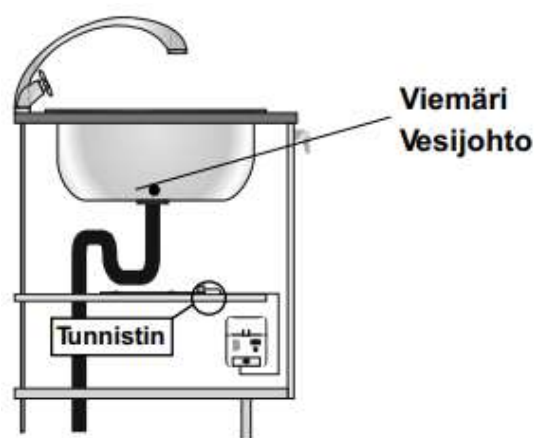

# 4.5 Window fresh air valves

## Biobe VS fresh air valve

### OPERATING AND MAINTENANCE INSTRUCTIONS

A fresh air canal on the upper window frame has a Biobe valve and possibly a filter unit installed above it. Functional ventilation requires fresh air intake from the outside of the apartment. Keep the valve at least partially open to avoid uncontrollable flow of air under doors, from the mail box or other gaps. Your apartment has a lot of moisture that stems from breathing, cooking and washing. If this moisture is not removed, your apartment is exposed to the risk of breeding different microbes and mould. Smell that transfers through vents or through the staircase from one apartment to another is one of the symptoms of lacking ventilation.

Biobe valve is completely open when both handles point outwards and closed when the handles point inward. To leave the vent partially open, set one of the handles to face outwards and the other one to face inwards.

It is recommended to clean the Biobe filter strip twice a year. Remove the valve by loosening the screws that attach it to the window frame. The cellular plastic filter that is inside the filter housing can be washed in a soap solution. Vacuum clean the air duct and put the parts back in their place. Install the filter housing so that its smaller vent is towards the valve closing system.

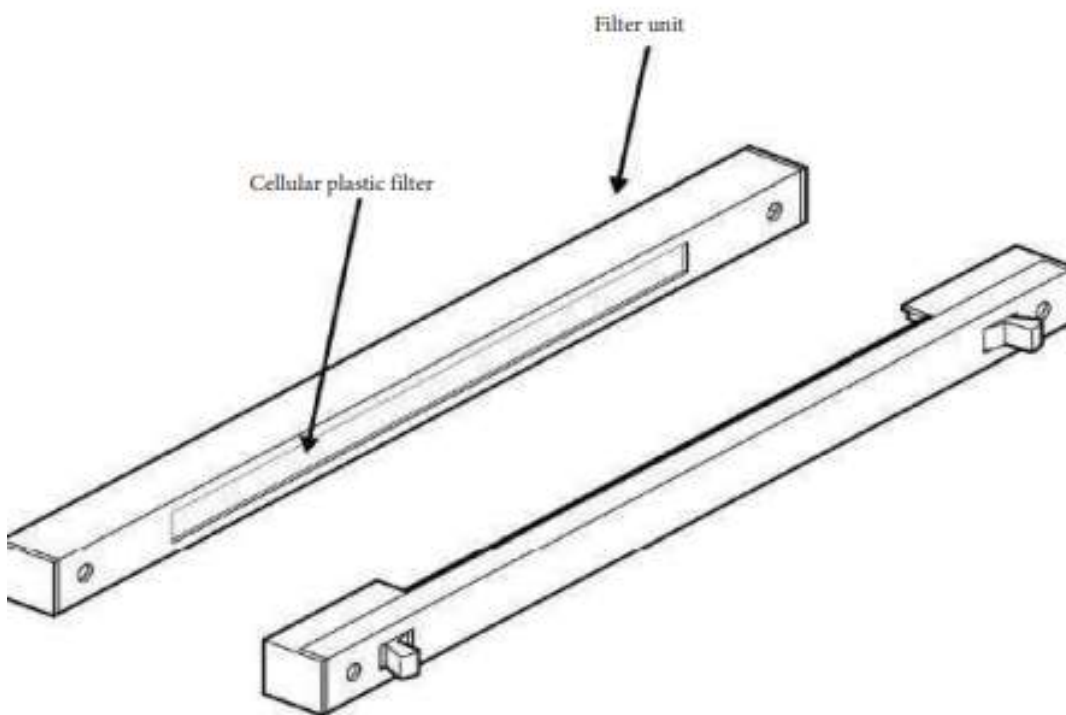

○ ■■■ ○	open valve	○ ■■■ ○
○ ■■■ ○	closed valve	■ ■ ■ ○
○ ■■■ ○	half-open valve	○ ■ ■ ■ ○
○ ■■■ ○	half-open valve	■ ■ ■ ○

**Biobe Oy**  
 Suvilahdenkatu 10 B  
 FI - 00580 Helsinki  
 +358 9 7743 270  
 +358 9 7743 2720  
 biobe@biobe.fi

## 4.6 Air valves

The valve should be cleaned from time to time with a damp cloth. Do not remove any parts. Only superficial cleaning.

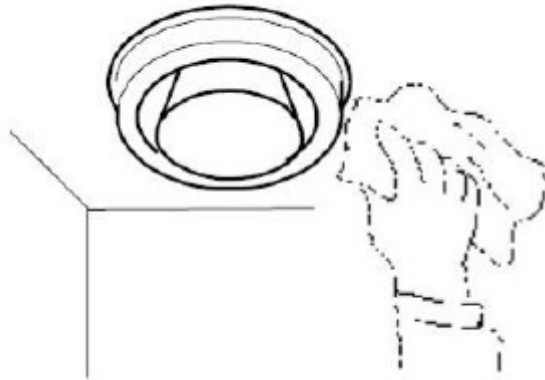

### Valves above shared apartment doors

The transfer air valve above the doors in the shared apartments should be vacuumed a few times a year. If necessary, wash the device with warm water and detergent.

Remove the valve body from the mounting frame for cleaning. Finally the body is pressed back onto the mounting strips in the mounting frame.

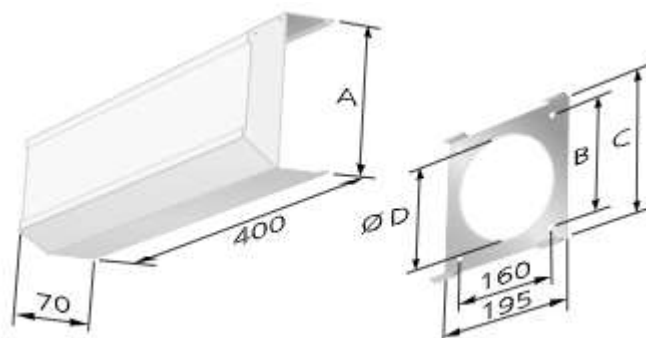

## 4.7 Floor drain

### Floor drain cleaning

The floor drain needs to be cleaned at least once a year. The drain may start to smell if it is dirty or dried out. A foul odor may be a sign of trap displacement or gasket damage. Cleaning is advised when the water flow has slowed down or the drain smells. Remove the grating off the floor drain.

Separate the trap from the floor drain by lifting the blue handle. Wash the trap and the floor drain thoroughly; rinse both. The trap may be stuck if it has been unmoved for a long time. The black flow regulator of the side inlets is also removable for cleaning. After cleaning, please check if the trap's grey lip seal is in place and wet it for example with soapy water. Install the trap into position in the floor drain and press it down carefully into place. Press the grating back down into place as well.



## 4.8 Electric Central

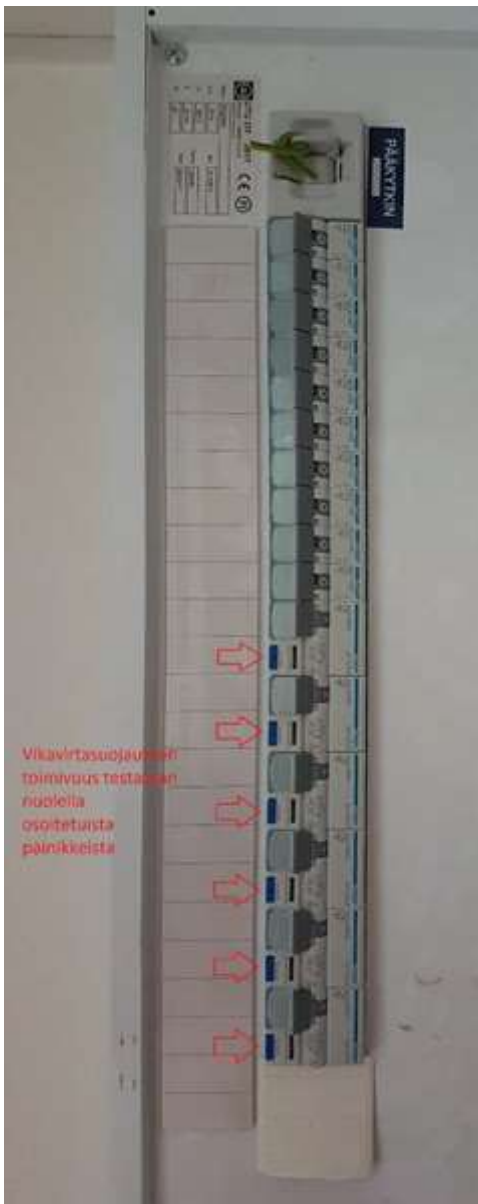

### Testing of bathroom residual-current device (RCD)

NOTE! Your bathroom is equipped with a RCD socket. The RCD should be tested regularly for example, quarterly.

The control panel has a test button, in which case the fault current should be triggered. Once the RCD is tested, the RCD is reset to position I.

### Testing of other RCDs

If any lamp is not working or there is no power to the socket and there is no power failure, check with the control panel whether any circuit breaker or circuit breaker has tripped.

If any circuit breaker or RCD is present In the 0 position, turn it back to position 1. If it does not stay on, contact your service company

## 4.9 Light bulbs

All the lights installed in the apartment are LED lights.  
The bulbs must be replaced by a service company.

# 5. GUIDE FOR RESIDENTS

## Is there something that needs to be repaired in your apartment or the property

You can submit fault reports concerning your apartment, the property and the outdoor areas via the fault report form on the Hoas website. Through the fault report form, a detailed description of the fault is passed efficiently and accurately all the way to the property maintenance company, along with the tenant's permission for the maintenance staff to enter the apartment. On the form you can also specify whether they may use the master key to enter and inform us of any pets that may be in the apartment. For these reasons, we do not accept fault reports over the phone or via email.

If you want to send photos of the faults please mail them to [maintenance@hoas.fi](mailto:maintenance@hoas.fi). Unfortunately it is not possible to attach photos to the fault report.

For more information about maintaining the apartment and responsibility of tenant you can find from our webpage [hoas.fi](http://hoas.fi), taking care of your home - section.



Our responsibility chart clarifies who is responsible for repairs and maintenance. The tenant must always notify Hoas of any faults in the apartment. The tenant is required to maintain the apartment carefully. Any costs caused by carelessness, improper handling or negligence will be charged to the tenant according to the tenant charge sheet.

	Responsibility	Additional instructions
<b>FIRE ALARMS</b>		
Purchasing and maintaining a fire alarm	Tenant	
Maintaining, repairing and replacing a mains-powered fire alarm system (tenant must check that it is operational)	Hoas	If you are not sure which kind of system is used in the property, you can find out in hoas.fi
<b>FIXED APPLIANCES, EQUIPMENT AND FIXTURES IN THE APARTMENT</b>		
Changing light bulbs; also the bulbs in the refrigerator, oven and range hood	Tenant	
Fuses in the apartment fuse box: changing blown fuses / resetting an automatic fuse back to working state	Tenant	
Testing the RCD / switching it back to working position	Tenant	For instructions, see e.g. Hoas.fi
Defrosting the freezer and cleaning the defrosting drain hole in the refrigerator	Tenant	Do not use a knife or other sharp object when defrosting the freezer
Purchasing an antenna cable or internet cable	Tenant	Internet cable needs to be an RJ-45 ethernet cable
Apartment lights and terminal block / ceiling connection box hook	Tenant	If any parts of the connection box are missing when moving in, the tenant must notify Hoas
Repairing and replacing light switches, power sockets, network sockets, TV aerial and phone sockets	Hoas	
Repairing or replacing the fixed appliances, furniture or equipment in the apartment	Hoas	
<b>HEATING</b>		
Measuring the temperature in the apartment	Tenant	The temperature should be 20 degrees or higher in the living area
Repairing or replacing radiators or their parts, and purging air out of radiators.	Hoas	
<b>VENTILATION</b>		
Cleaning the range hood grease filter	Tenant	For instructions, see e.g. Hoas.fi
Cleaning the exhaust and fresh air vents	Tenant	For instructions, see e.g. Hoas.fi
Repairing and replacing the exhaust and fresh air vents and filters	Hoas	Never block the air vents or close them entirely under any circumstances!
<b>BATHROOM FIXTURES AND DRAINS</b>		
Cleaning the bathroom sink drain trap and the floor drain	Tenant	For instructions, see e.g. Hoas.fi
Cleaning the kitchen sink drain trap	Tenant	In the kitchen, using liquid drain cleaner is enough; you do not need to dismantle the drain trap.
Unblocking a clogged drain, if cleaning the drain trap and/or the floor drain is not sufficient	Hoas	If the tenant could have unclogged the drain (hair in the floor drain etc.), the maintenance visit will be charged from the tenant
Installation of a washing machine or dishwasher	Tenant	To use a washing machine, you must have home insurance
Plugging the washing machine water inlet and outlet pipes	Tenant	If the plugs left for the tenant do not fit, the tenant must find plugs that do fit
Purchasing the plugs for sinks and bathtubs	Tenant	If there are no plugs when you move in, let Hoas know
Fixing and replacing bathroom fixtures, like the sink	Hoas	Any unintentional damage caused by the tenant will be charged according to the tenant charge sheet
<b>WINDOWS AND DOORS</b>		
Installing shades or Venetian blinds	Tenant	Must be left in place when moving out
Adding the tenants' names to the front door of the apartment	Tenant	Must be removed when moving out
Installing a peephole or safety chain in the apartment front door	Tenant	Must be left in place when moving out
Repairing or replacing window or door frames, insulation or glass panes	Hoas	
<b>KEYS AND LOCKS</b>		
Installing a security lock	Tenant	Only with Hoas' permission and according to instructions
Repairing a lock and recoding a lock	Hoas	Will be charged from the tenant if necessary
<b>SURFACES</b>		
Painting the apartment and repairing/replacing the flooring material	Hoas	The tenant must never make structural or any other kind of changes to the apartment without permission from Hoas
<b>OUTDOOR AREAS</b>		
Removing snow from stairs/paths that lead only to the tenant's apartment	Tenant	





## Maintaining the apartment - cleaning

As a tenant it is your responsibility to carefully maintain the apartment. You can check the further instructions below. If you are uncertain of how to do specific things e.g. clean kitchen range hood filter or defrost the freezer you can find instructions from Hoas web page among others at [www.hoas.fi/en/tenants/#taking-care-of-your-home](http://www.hoas.fi/en/tenants/#taking-care-of-your-home)

### Remember as a part of your daily life

- Clean the hob and kitchen surfaces and wash the dishes after cooking, especially in a shared apartment
- Take the bins out when necessary – never store full bin bags in the apartment
- If you don't want junk mail add "ei mainoksia" (no ads) sticker on your apartment's door
- Dry the bathroom floor (and walls) after taking a shower and remove hairs from floor drain strainer

### Weekly cleaning (do at least every second week)

- Put the knick-knacks where they belong
- Dust and remove stains and grime, clean light switches and doors if necessary
- Wipe the kitchen counters, hob, sink, taps and tiles if needed – remove possible stains from the cupboard doors and walls
- Hoover and wash the floors, do not use too much water to wash the floors
- Wash the toilet seat, sink and taps
- If there are grime gathering to bathroom walls or floors wash them carefully before any limescale forms to the surfaces

### Annual cleaning (1-2 times per year)

- Clean the windows (when outside temperature is above 0 degrees)
- Clean the air vents
- Clean the grime from surfaces that are often touched (light switches, door handles)
- Dust the spots that are harder to reach – behind the radiator, from top of high closets etc.

#### Kitchen

- Clean the refrigerator and defrost and clean the freezer
- Clean the oven, hob and trays thoroughly
- Empty the cupboards and clean them, clean also the cupboard doors
- Clean the kitchen range hood filter and the range hood itself

#### Bathroom

- Wash the bathroom walls, floors and seaming carefully – if necessary use a brush and chlorite
- Remove the chalk
- Clean the floor drain
- Clean the sink's water trap
- If needed wipe the bathroom ceiling





